

BACKYARD PROJECTS

from

Georgia-Pacific



GAZEBO

GAZEBO

MATERIALS LIST

- 3 2" x 8" x 12' treated lumber, miter cut 69"
- 4 2" x 8" x 12' treated lumber
- 3 2" x 8" x 10' treated lumber
- 1 4" x 4" x 12' treated lumber
- 3 2" x 6" x 8' treated lumber
- 18 2" x 6" x 10' treated decking
- 6 4" x 4" x 8' treated lumber
- 3 2" x 4" x 16' treated lumber
- 20 1" x 4" x 16' treated lumber
- 2 4" x 4" x 10' treated lumber
- 6 2" x 8" x 8' treated band beams

SEATING

- 2 2" x 4" x 10' treated lumber
- 1 2" x 4" x 12' treated lumber
- 10 2" x 4" x 12' treated lumber

RAILING

- 6 2" x 4" x 12' treated lumber
- 48 2" x 2" x 34" treated out-turned spindles

OTHER

- 3lb. 8d nails
- 2lb. 10d nails
- 4lb. 16d nails
- 12 8' furring
- 2 2" x 2" x 8' stakes
- 3 80lb. concrete mix sacks
- 6 3/8" x 5 1/2" galvanized carriage bolts
- 12 3/8" x 7" galvanized carriage bolts

NOTE: All wood products are pressure treated with Chromated Copper Arsenate preservative. All wood products in contact with the ground should be treated to a .40 ground contact retention.

NOTE: In some applications you may use screws instead of nails for better hold down power.

TIP: Use water repellent or stain with water repellent when your job is finished to help protect your pressure treated wood from splitting, checking, and warping.

Georgia-Pacific



Georgia-Pacific Corporation makes no warranties expressed or implied regarding this plan and specifically disclaims the warranties of merchantability and fitness for a particular purpose. Check with an architect or a building expert to make sure that this plan is appropriate to your situation and meets local building codes. Read carefully the consumer information sheet on pressure treated wood before starting construction.

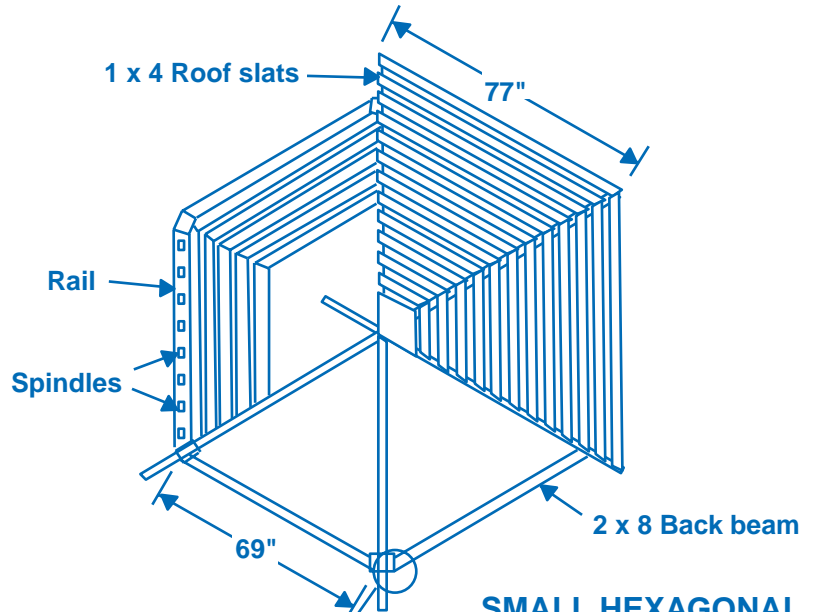

SMALL HEXAGONAL GAZEBO



JOINER PLATE FOR RAFTERS

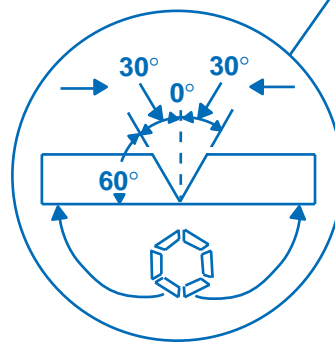
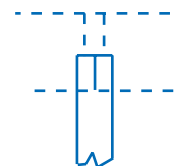

MITER CUTS FOR HEXAGON

POST FRONT VIEW



POST TOP VIEW

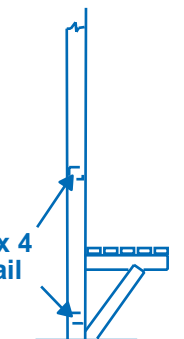

SEAT DETAIL

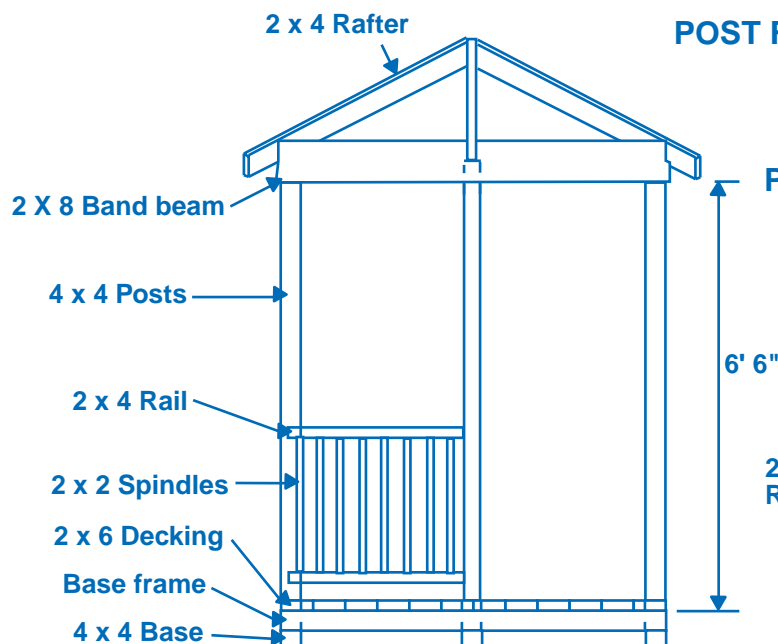

Safety Dispatch

Build Safely with Pressure-Treated Wood

Whether you're building a new planter or replacing your deck, Georgia-Pacific pressure-treated wood is the high performance decking choice. The projects you build with Georgia-Pacific pressure-treated wood products should last a long time. So, it makes good sense to build in a craftsmanlike manner. Here are some helpful tips to make your job easier and look better.

1. Recommended Fasteners.

Use only hot-dipped galvanized or stainless steel fasteners, connectors and hardware to help safeguard the structural integrity of projects built with ACQ treated wood.

As a minimum requirement for use with ACQ treated wood, hot-dipped galvanized coated fasteners should conform to ASTM Standard A153 and hot-dipped galvanized coated connectors should conform to ASTM Standard A653 (Class G-185). In demanding applications, such as treated wood foundations and playground equipment, use of stainless steel fasteners and connectors should be utilized and may, in fact, be required by building codes.

Electroplated galvanized fasteners are not recognized as being corrosion resistant for exterior applications. Aluminum should not be used in direct contact with CCA or ACQ treated wood.

2. Nail bark side up.

Always nail boards bark side up (annual rings arc upward) to reduce cupping. Nail thin boards to thicker boards to help maintain structural integrity.

3. Drill pilot holes.

Especially when nailing near the edge or end of a board, it's a good idea to drill pilot holes for your fasteners.

4. Butt boards tightly.

Butt decking boards together firmly. As drying occurs, some shrinkage can be expected.

5. Apply a weather-resistant finish.

Any exposed wood, pressure treated or not, should be protected from the weather. Application of a finish coat of clear or semi-transparent water-repellent stain will help to minimize warping, checking, or splitting. The finish coat should be applied immediately to untreated wood and to pressure treated wood as soon as the surface is dry.

Did you know...?

- Pressure-treated wood may be painted or stained to match any outdoor color scheme. High-quality latex-based paints and oil or latex stains are recommended. Make sure the wood is dry and free from surface deposits before applying any coating.
- Water repellent coatings can be applied to enhance the long-term weathering performance.
- Only wood that is visibly clean and free of surface residue should be used for patios, decks and walkways.
- To help maximize surface protection and to keep your wood looking better longer, GP recommends that a surface applied water repellent be applied every two years.

Safety First

Pressure-treated wood is easy to work with. The following simple safety procedures are recommended.



- Do not burn treated wood. Toxic materials may be produced as part of the smoke or ashes.
- Clean up scraps & sawdust after construction and dispose by ordinary trash collection.
- Gloves should be worn to protect against splinters and abrasions.
- A dust mask should be worn when sawing, machining or sanding any wood to reduce the inhalation of wood dust. Whenever possible these operations should be performed outdoors to avoid indoor accumulations of airborne sawdust from treated wood.
- Appropriate eye protection should be worn to reduce the potential for eye injury from wood dust or particles and flying debris during machining and construction.
- After working with pressure-treated wood, thoroughly wash your hands and exposed areas thoroughly with mild soap and water before eating, drinking or using tobacco products.
- Because preservatives or sawdust may accumulate on clothes, they should be laundered before reuse. Wash work clothes separately from other clothing or household items with which you may have contact.
- Treated wood should not be used where it may come into direct or indirect contact with drinking water, except for uses involving incidental contact such as fresh water docks and bridges.

Use Site Precautions

ACQ treated wood may be used both inside residences (should be clean and free of surface residues) and outdoors. However, it should not be used in or on sites where it could come into contact with food, animal feed or drinking water. Examples of such sites are as follows:

1. Structures for storage or handling animal feed, (grain, silage, etc.) such as silos, feed troughs or bunks.
2. Use as kitchen countertops or cutting boards.
3. Use in construction of those portions of beehives which may come into contact with the honey.
4. Structures that would be in direct or indirect contact with drinking water, except for uses involving incidental contact such as residential fresh water docks and bridges. **ACQ treated lumber should not be used in salt-water immersion applications.**
5. Do not use ACQ treated lumber residues, such as sawdust and shavings, as mulch.

Interested
in building
a porch swing?
See our
project plans at
www.gp.com/build.

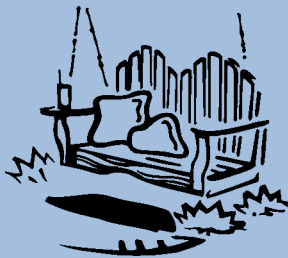

Q&A

Q. What kinds of projects are ideal for pressure-treated wood?

A. Choose GP pressure-treated wood for decks, porches, gazebos, planters, arbors and other outdoor structures. You'll enjoy the beauty of wood plus long-lasting performance.

Q. How do I dispose of unused wood?

A. Scraps and sawdust should be disposed with ordinary trash. Do not burn treated wood, as toxic materials may be produced as part of the smoke or ashes.

Q. What is ACQ?

A. Alkaline Copper Quaternary (ACQ) is a chemical solution used as a preservative treatment for wood to help provide long-term protection from rot, decay and termites. The main active ingredient in ACQ is copper, which has long been established as the most cost-effective preservative component used in preserving timber. Quat acts as the co-biocide in the ACQ preservative, providing additional protection from decay fungi and termite attack that copper alone would not control. Copper and quat solutions similar to ACQ are used for the control of fungi and bacteria in swimming pools and spas.

Q. How long has ACQ been in use?

A. For more than a decade, ACQ has been used in neighborhood playgrounds, backyards and other outdoor projects.